

7

Special Topics

Radiation Skyshine

Some radiation facilities are designed with little shielding in the ceiling above the accelerator. A problem may then arise as a result of the radiation scattered by the atmosphere to points at ground level outside the treatment room. Stray radiation of this type is referred to as skyshine, and the National Council on Radiation Protection and Measurements Report No. 51 (NCRP 1977) gives methods for the calculation of skyshine for accelerator facilities.

McGinley (1993b) has compared skyshine measurements made at an 18 MeV medical accelerator facility with values calculated using the techniques presented in NCRP Report No. 51. Measurements were made of the neutron and photon levels outside a treatment room housing a Varian 2100C. The roof above the accelerator was designed for weather protection only and offered little shielding for the primary beam and scattered radiation. The distance from the treatment room floor to the roof was 4.27 m, and the primary walls were constructed of concrete 2.22 m thick. The secondary walls were fabricated of concrete 0.99 m thick. Figures 7-1 and 7-2 show vertical section views of the treatment room shielding.

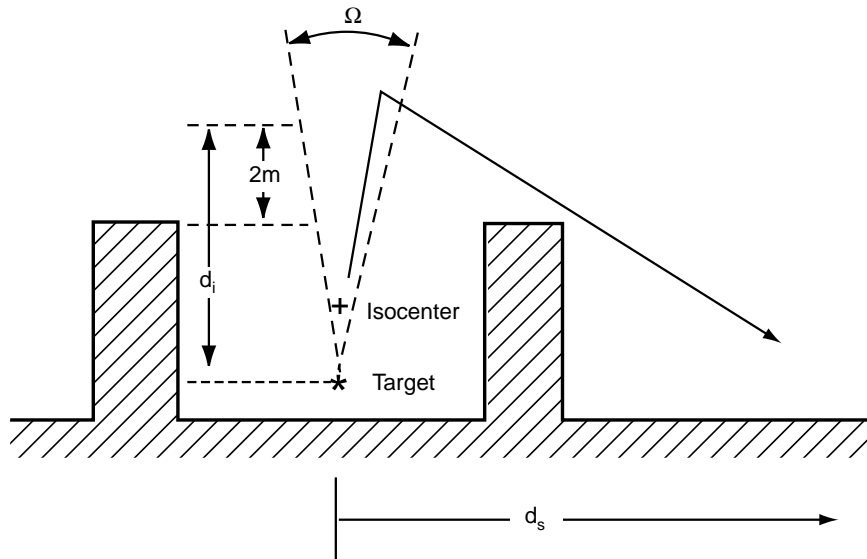

Figure 7-1. Simplified schematic showing the accelerator isocenter and target location for photon skyshine evaluation

An ionization chamber survey instrument was used to measure the photon dose with the accelerator operating at a rate of 6.67 cGy s^{-1} at a distance of 1 m from the target. In order to produce maximum skyshine, the beam was directed vertically up and the collimator was opened to maximum size ($40 \times 40 \text{ cm}^2$ at the isocenter). The x-ray dose was measured outside the accelerator room at 1 m above ground.

A neutron remmeter was used for the area survey outside the treatment room. Maximum skyshine was produced by closing the collimators and positioning the accelerator head at minimum distance from the roof, as shown in figure 7-2. The accelerator dose rate was set at 6.67 cGy s^{-1} at the isocenter.

NCRP Report No. 51 gives the following equation for calculation of the photon component of the skyshine radiation field.

$$B_{XS} = 4.02 \times 10^{-6} \frac{D(d_i d_s)^2}{(D_{i0} \Omega^{1.3})} \quad (7-1)$$

where

D = photon dose equivalent rate at ground level (nSv s^{-1})

d_s = distance (m) from isocenter to the point where the dose equivalent rate is D

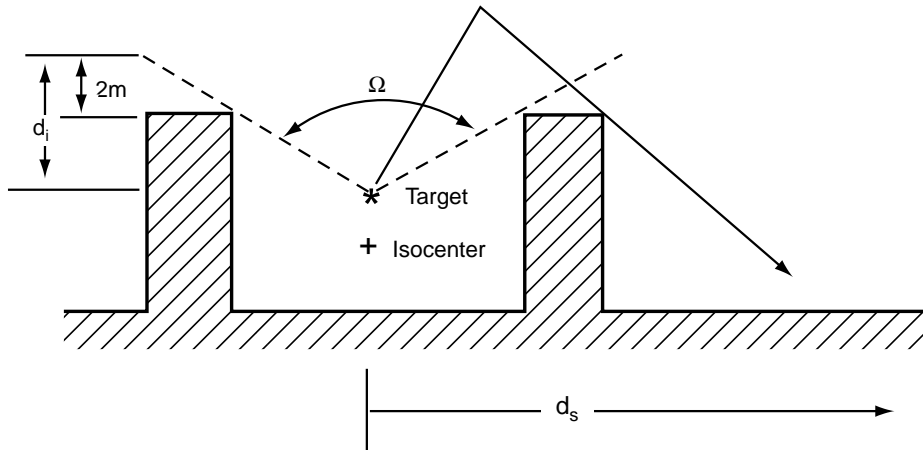

Figure 7-2. Irradiation conditions for the neutron skyshine evaluation

- d_i = distance (m) from x-ray target to a point 2 m above the roof
- D_{io} = x-ray dose rate at 1 m from the target (cGy s^{-1})
- Ω = solid angle of radiation beam (steradians)
- B_{xs} = roof shielding transmission ratio.

Equation 7-1 is based on measurements made near Cs-137 and Co-60 sources placed in a hole in the ground. Solving equation 7-1 for the skyshine dose equivalent rate gives equation 7-2.

$$D = 0.249 \times 10^6 \frac{B_{xs} D_{io} \Omega^{1.3}}{(d_i d_s)^2} \quad (7-2)$$

The following equation is given in NCRP Report No. 51 (NCRP 1977) for neutron skyshine.

$$B_{ns} = 1.19 \times 10^{-5} \frac{H d_i^2}{\Phi_o \Omega} \quad (7-3)$$

where

- H = nSv s^{-1} due to neutrons at ground level
- B_{ns} = roof shielding transmission ratio for neutrons
- d_i = distance from target to ceiling plus 2 m
- Φ_o = neutron fluence rate ($\text{cm}^{-2} \text{s}^{-1}$) at 1 m from the target
- Ω = solid angle of shield walls.

Equation 7-3 is to be used for distances d_s less than 20 m and is based on measurements made at a research accelerator. Solving for the neutron skyshine dose equivalent rate, H , gives the following equation.

$$H = 0.84 \times 10^5 \frac{B_{ns} \Phi_o \Omega}{d_i^2} \quad (7-4)$$

Example Calculation

1. Photon Skyshine

The following parameters are used for the room shown in figure 7-1 when the photon skyshine level is calculated.

$$B_{xs} = 1.0 \text{ (no ceiling shield)}$$

$$d_s = 10.6 \text{ m}$$

$$D_{io} = 6.67 \text{ cGy s}^{-1}$$

$$d_i = 5.97 \text{ m}$$

$$\Omega = 0.122 \text{ ster}$$

The solid angle for a beam (see figure 7-3) with a circular cross section is $\Omega = 2\pi (1 - \cos\theta)$, where θ is 11.3° for a $40 \times 40 \text{ cm}^2$ beam (which is a good assumption for the maximum collimator opening).

Introducing the values into equation 7-2 gives:

$$D = 0.249 \times 10^6 (1 \times 6.67 \times 0.122^{1.3}) / (5.97 \times 10.6)^2$$

$$D = 26.9 \text{ nSv s}^{-1}.$$

2. Neutron Skyshine

The following values are used in equation 7-4.

$$B_{ns} = 3.36 \times 10^{-10} \text{ Sv cm}^{-2} \text{ (from NCRP Report No. 51 for no ceiling shielding and a neutron energy of 1.7 MeV).}$$

$$\Phi_o = 6.6 \times 10^5 \text{ cm}^{-2} \text{ s}^{-1} \text{ at 1 m from the target when the x-ray dose rate is } 6.67 \text{ cGy s}^{-1}. \text{ This value is based on measurements made by the author for several 18 MeV accelerators.}$$

$$\Omega = 2.71 \text{ ster (see figure 7-2). The distance from the floor to the isocenter is 1.3 m, and the wall height is 4.97 m. The distance from the isocenter to the wall is 3.86 m. Note that the solid angle is based on the room size and not the beam size when the neutron skyshine is determined.}$$

$$d_i = 4.67 \text{ m}$$

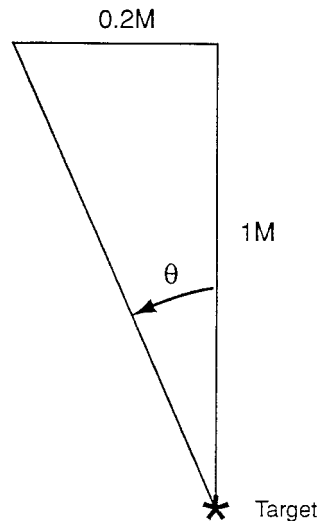

Figure 7-3. Beam geometry

From equation 7-4 we have

$$H = 0.84 \times 10^5 (3.36 \times 10^{-10}) (6.6 \times 10^5) (2.71) / 4.67^2$$

$$H = 2.3 \text{ nSv s}^{-1} \text{ for all points from the outer wall surface to 20 m from the isocenter.}$$

Table 7-1 shows the measured and calculated photon skyshine dose rates as a function of distance from the isocenter (d_i). As can be seen, the measured values increase as one moves away from the wall (reaching a maximum at a distance of 13.6 m from the isocenter) and decrease as one moves past the point of maximum dose. This behavior is caused by the increase in the scattering cross section with a decreased scattering angle. A rule of thumb says that the maximum dose rate should occur at a distance from the outer wall surface that is equivalent to the wall height. Note that the calculated values continually decrease with distance from the isocenter. As shown in Table 7-1, the agreement between the calculated and measured values is poor; for distances greater than about 10 m from the isocenter, the NCRP method underestimates the photon dose rate. Table 7-2 gives the neutron skyshine levels measured with the accelerator operating at a dose rate of 6.67 cGy s^{-1} at the isocenter. At all points the measured neutron dose equivalent rate exceeded the value of 2.3 nSv s^{-1} predicted by the NCRP method.

Table 7-1 Measured and calculated x-ray skyshine for an 18 MeV accelerator with no ceiling shield*

<i>Distance from isocenter d_s (meters)</i>	<i>Measured photon rate ($nSv s^{-1}$)</i>	<i>Calculated photon rate ($nSv s^{-1}$)</i>	<i>Ratio measured/calculated</i>
7.5 (at wall)	13.9	56.2	0.25
9.4	31.2	35.4	0.88
10.6	41.7	26.9	1.5
13.6	43.7	17.4	2.5
19.2	27.8	8.3	3.3
25.4	20.8	4.9	4.2
33.0	15.3	2.9	5.3
48.3	6.9	1.3	5.3

*Dose rate at isocenter 6.67 cGy s^{-1} , beam size $40 \times 40 \text{ cm}^2$, and beam directed vertically up.

Table 7-2 Measured neutron skyshine for an 18 MeV accelerator with no ceiling shielding*

<i>Distance from isocenter d_s (meters)</i>	<i>Measured neutron dose equivalent rate ($nSv s^{-1}$)</i>
5.14	19
8.50	58
11.2	52
14.3	42
17.3	36
18.9	29
20.8	23

*Dose rate at isocenter 6.67 cGy s^{-1} with collimators closed.

The author has made neutron and photon measurements at two 18 MeV accelerators, each with a 0.91 m thick concrete ceiling slab. For each room, the radiation at ground level was found to be less than 0.4 nSv s^{-1} for both neutrons and photons. For these measurements the accelerator was operated at a dose rate of 6.67 cGy s^{-1} , and the beam was directed up.

Side Scatter

In addition to skyshine, one should be aware that radiation passing through a thin ceiling slab can be side scattered to adjacent multi-story buildings. For example, it was found for a 0.91 m thick concrete ceiling that the dose rate at roof level due to photons was 17 nSv/s at 4.88 m and 2.8 nSv/s at 15.2 m horizontal distance from the point where the beam center exits the ceiling slab. If the thickness of the ceiling is increased to 1.68 m, the side scatter dose rate becomes less than 0.14 nSv/s at roof level. These dose rates were produced by an 18 MeV accelerator operating at 6.67 cGy per minute at isocenter with the beam pointing vertical up and the collimator opened to maximum field size ($0.40 \times 0.40 \text{ m}^2$).

Zavgorodni (2001) has developed a method of calculating the dose due to side scattering of radiation to multi-story buildings adjacent to an accelerator room. The dose produced by radiation scattered in passing through the ceiling slab is given by the following equation.

$$D_i = D_o (FS)^2 f(\theta) / (R^2 10^{1+(t-TVT1)/TVT2}) \quad (7-5)$$

where

R = distance from the center of a vertical beam after it exits the roof slab to the point of interest

FS = field size at the isocenter

t = thickness of the ceiling slab

TVT1/TVT2 = first and second tenth value thicknesses of concrete

D_o = dose rate at the isocenter.

The angular distribution of scattered photon $f(\theta)$ was obtained by Monte Carlo calculations and values are given in Table 7-3. The angle between the beam axis and R is represented by the symbol θ . It was found that the function $f(\theta)$ has little dependence on the beam energy and shield thickness.

Table 7-3 Angular distribution function $f(\theta)$ of photons exiting through the roof of an accelerator room

θ	$f(\theta)$
20	3.8×10^{-1}
30	2.6×10^{-1}
40	1.6×10^{-1}
50	1.0×10^{-1}
60	6.5×10^{-2}
70	3.5×10^{-2}
80	1.4×10^{-2}
85	5.0×10^{-3}

Example Calculation

Determine the side scattered photon dose rate for the example given above where the dose rate was 17 nSv/s at a distance $R = 4.88$ m, $D_o = 6.66$ cGy/s at the isocenter, $FS = 0.40$ m, $t = 0.91$ m, and θ is approximately 85° .

$$D_i = D_o (FS)^2 f(\theta) / (R^2 10^{1 + (t - TVT1)/TVT2})$$

$$D_i = 6.66(0.4)^2 (5.0 \times 10^{-3}) / (4.88^2 \times 10^{1 + (0.91 - 0.47)/0.43})$$

$$D_i = 21 \text{ nSv/s}$$

Problems

1. Determine the neutron and photon skyshine for the accelerator room of problem 7 in chapter 2 at one wall height outside the east wall. Assume that there is no ceiling shielding and that the accelerator produces an 18 MV x-ray beam. The dose rate at the isocenter is 400 cGy min^{-1} , and the beam size is $40 \times 40 \text{ cm}^2$.
2. What is the minimum ceiling concrete thickness needed for the accelerator room, described in the example given in this chapter, that will meet the requirement of 2 mrem for one week of operation for uncontrolled areas? Assume that the workload is $1 \times 10^5 \text{ cGy}$ per week and that the use factor is $1/4$ for the up direction. Use the measured values for the calculation.

3. Calculate the dose rate due to side scattered photons to the third story of an adjacent building that is 15 m horizontal from the point where the beam exits the treatment room ceiling. The distance between floors is 4.3 m and the concrete ceiling is 0.30 m thick. The accelerator's energy is 18 MeV and it is located on grade. The dose rate at the isocenter is 6.66 cGy/s.

HVAC Openings

A rather large opening is needed in the secondary barrier for the HVAC duct to enter the treatment room. In most cases this opening is approximately $0.4 \times 1.2 \text{ m}^2$ in cross section above the maze door. Table 7-4 shows typical values of the neutron and photon dose equivalent rates at the surface of the HVAC duct for several mazes of different lengths (d_2 of figure 5-1). Each room housed an 18 MeV accelerator, and the measurements were made with a dose rate of 400 cGy s^{-1} at the isocenter and the collimator open to $0.4 \times 0.4 \text{ m}^2$ size.

As can be seen from Table 7-4, the radiation level adjacent to the HVAC duct is low if the maze length (d_2) is on the order of 5 m. For a short maze with d_2 less than 3 m, a shielding baffle may be needed at the HVAC penetration. Figure 7-4 shows several designs that can be used to shield the opening for the HVAC duct. The duct wrap technique, which is shown in figure 7-4, is carried out by surrounding the duct on all sides with the shielding material, starting at the point where the duct enters the maze and ending at a point 1.2 to 1.5 m down the maze. For a high-energy accelerator, 1.0 cm of lead and 2.54 cm of polyethylene are commonly used to enclose the duct, and a low-energy accelerator needs about 0.6 cm of lead to shield the duct. A dose equivalent reduction of approximately a factor of four for neutrons and a factor of two for photons will be produced by a 1.2 m long duct wrap shield composed of 2.54 cm of polyethylene and 1.0 cm of lead for a maze with d_2 equal to 3.6 m. As can be seen from Table 7-4, the neutron and photon dose equivalent rates change with the beam direction, and the maximum radiation level is produced by locating the accelerator head as close as possible to the maze inner opening (beam on wall A).

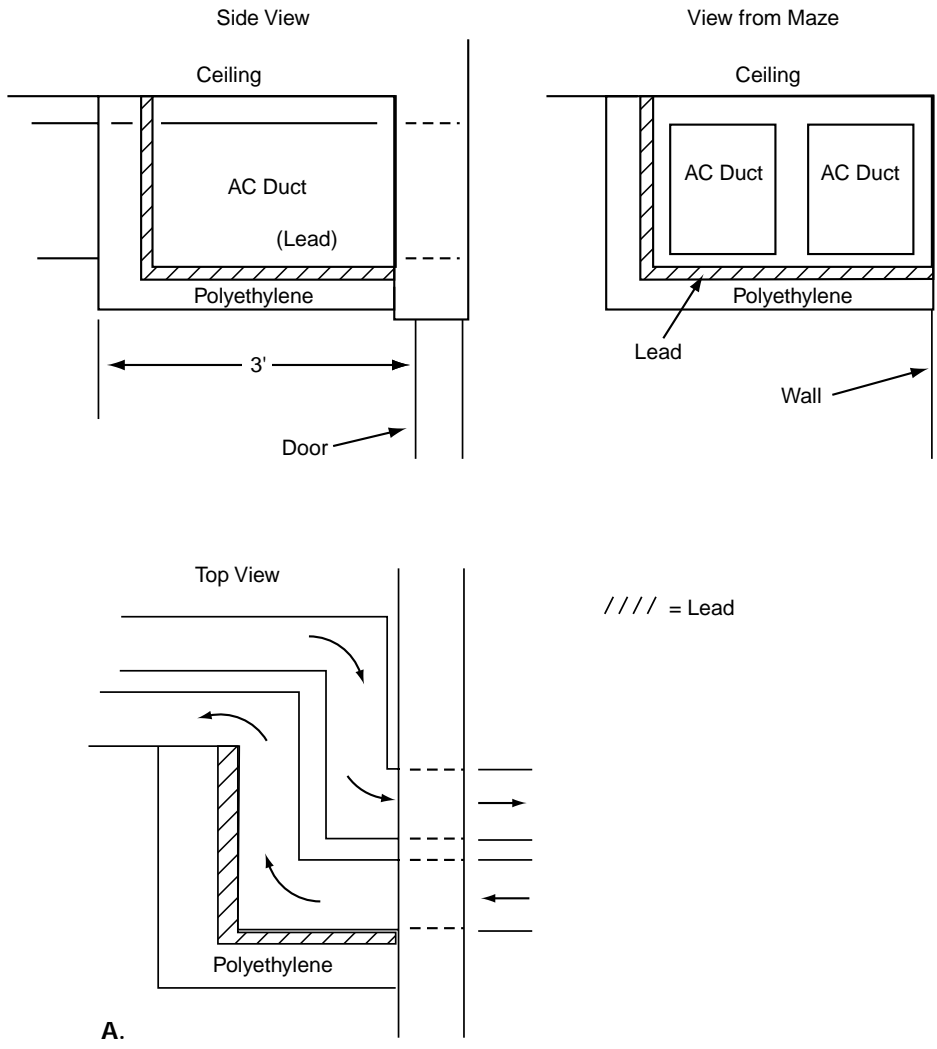
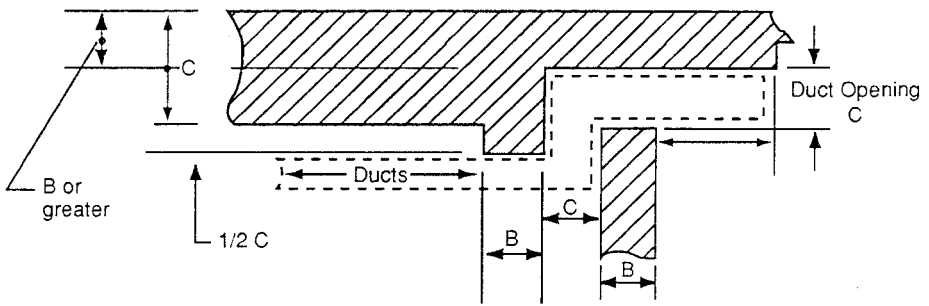
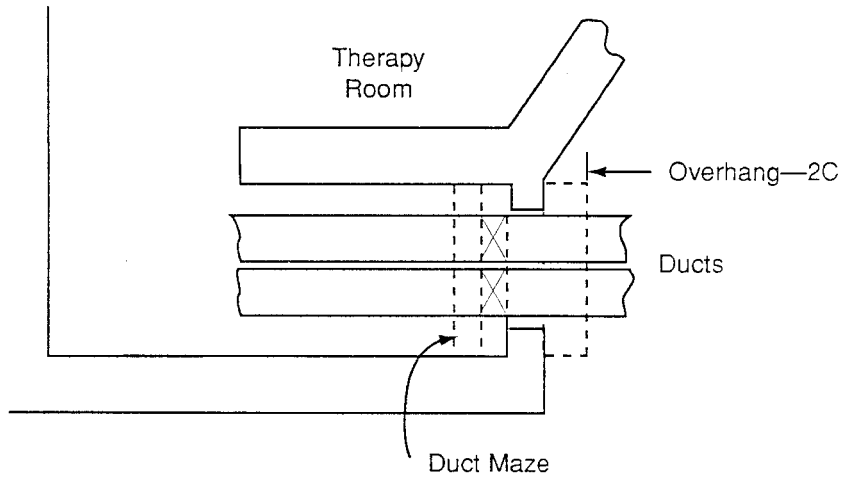

Figure 7-4. HVAC duct shields. A. HVAC baffle. B. Concrete baffle. C. Duct wrap.



B.



C.

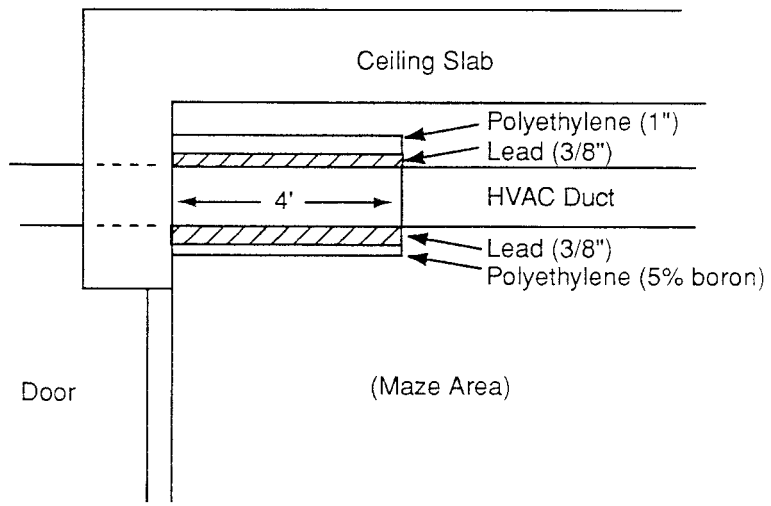

Table 7-4 Neutron and photon dose equivalent levels adjacent to the HVAC duct*

Room	Beam direction [†]	Neutron dose equivalent (nSv s ⁻¹)	Photon dose equivalent (nSv s ⁻¹)	d ₁ (m)	d ₂ (m)
1	down	1.22	2.77	5.2	5.2
	on wall C	2.22	1.67		
	on wall A	1.66	3.33		
	up	1.39	2.60		
2	down	9.16	15.3	5.2	2.2
	on wall C	13.9	9.72		
	on wall A	31.7	22.2		
	up	8.72	13.7		

*The dose rate at the isocenter is 6.67 cGy s⁻¹ and the field is 0.4 × 0.4 m². None of the HVAC ducts are shielded.

[†]See figure 3-1 for beam directions.

Figure 7-4 also shows a shadow shield and a concrete wall baffle for the HVAC penetration. The shadow shield requires about the same thickness of shielding material as the duct wrap method. The duct is mounted near the ceiling slab and only the bottom and two sides are shielded. In place of using a shadow shield, a concrete wall baffle can be placed above the maze door to reduce the radiation level at the HVAC opening. Note that in figure 7-4 the dimension (C), which is the height of the duct, is also related to several of the baffle dimensions.

Ozone Production

Ozone (O₃) is produced by radiation interactions with oxygen (O₂) in the air of the treatment room. If a medical accelerator is operated in the electron mode, more ozone is produced than when the photon mode is used. Ozone is considered an injurious and potentially lethal gas at a level of a few parts per million (ppm), and a maximum permissible concentration (MPC) of 0.1 ppm has been recommended (NCRP 1977). The odor produced by a concentration of 0.1 ppm is detectable by most individuals. The concentration, C, of ozone in ppm after the accelerator has been operated for a length of time, t, is given by

$$C = \frac{C_o G E S_{col} I d}{N V (Q/V)} \times \left(1 - e^{-(Q/V)t}\right) \times 10^9 \quad (7-6)$$

where

C_o = fraction by weight of O_2 in air (0.232)

G = ozone production by electron irradiation of air (approximately 6 molecules per 100 electron volts)

E = the number of electronic charges per milliamp per second of electron beam current ($6.28 \times 10^{15} \text{ mA}^{-1} \text{ s}^{-1}$)

S_{col} = collision stopping power of the electron (about 2.7 KeV cm^{-1} from 2 to 25 MeV)

I = average external electron beam current (mA)

d = distance of travel of the electrons in air (cm)

N = Avogadro's number (6.02×10^{23} molecules per 22.4 liters air)

V = room volume in liters

Q = room ventilation rate (liters s^{-1})

Q/V = number of room air changes per second

t = irradiation time(s).

In deriving equation 7-6 it has been assumed that there is no dissociation of the ozone during the irradiation. If we consider a 6 MeV electron beam with an average external beam current of 2 microampere, 100 cm beam travel, a room volume of 100,000 liters, and a ventilation rate of greater than six room changes per hour, we find that the MPC level of ozone will not be reached for an infinitely long irradiation. When total skin electron therapy is performed with a low-energy electron beam, a travel distance of approximately three meters and high beam currents are used, which can produce greater levels of ozone than the example given above. However, for normal clinical use of electron beams, a room ventilation rate of about three room changes per hour is more than adequate for health protection. The ozone level produced by photon beams is in general less than that due to electron beams.

Example Calculation

Determine the time required to reach the MPC for ozone for a 1×10^5 liter room volume and an electron beam current of $20 \mu\text{A}$. The beam path length in air is 100 cm, and the ventilation rate is 2.0 room changes per hour.

Expressing Q/V in room changes per s gives

$$Q/V = 2.0/3600 = 5.56 \times 10^{-4} \text{ s}^{-1}.$$

From equation 7-6 we have

$$C = \frac{C_o \text{GES}_{\text{col}} \text{Id}}{NV(Q/V)} \times \left(1 - e^{-(Q/V)t}\right) \times 10^9$$

and solving for t gives

$$t = 0.19 \text{ hours} = 11.4 \text{ minutes.}$$

Problem

Determine the ozone concentration for the room described above 10 minutes after the end of a 11.4 minute irradiation.

Air Activation

Air is made radioactive by medical accelerators operating above 10 MeV primarily by the photoneutron reactions shown below.

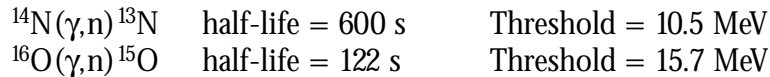

Each reaction produces a positron emitter with a relatively short half-life. The patient and radiotherapy technologist are exposed to positrons and annihilation photons with an energy of 0.511 MeV. Table 7-5 presents the maximum permissible concentration in air (MPC_a) based on a 40-hour work week and the typical volume of a treatment room. As can be seen from Table 7-5, the limiting condition for air activation is due to skin irradiation by positrons from oxygen and nitrogen.

The activity of ^{13}N or ^{15}O per unit volume of air (C) produced in the treatment room by a $20 \times 20 \text{ cm}^2$ beam is given by equation 7-7 (McGinley et al. 1984).

$$C = \frac{(D/16.7)(P)(1 - e^{-(\lambda+Q/V)T_r})(e^{-(\lambda+Q/V)T_s})}{V(\lambda + Q/V) / \lambda} \quad (7-7)$$

where

C = concentration (Bq m⁻³)

D = dose rate at maximum build-up depth (mGy s⁻¹)

P = production rate of ¹³N or ¹⁵O at a dose rate of 16.7 mGy s⁻¹ (Bq kg⁻¹ of oxygen or nitrogen)

Q = room ventilation rate (m³ s⁻¹)

V = volume of room (m³)

λ = decay constant for ¹³N or ¹⁵O (s⁻¹)

T_r = irradiation time (s)

T_s = time after end of irradiation (s).

Values of the production rate (P) have been reported by McGinley et al. (1984) for betatron-produced x-ray beams. If one uses these values of P for a linear accelerator, a slight overestimation of the air concentration of ¹³N and ¹⁵O will result. Table 7-6 shows values of P for selected x-ray megavoltages (McGinley et al. 1984).

Table 7-5 MPC_a values and dose limits (D_i) for air activation products

<i>Isotope</i>	<i>Organ</i>	<i>MPC_a</i> (Bq m ⁻³)	<i>D_i</i> (nSv s ⁻¹)	<i>Radiation type</i>
¹³ N	skin	1.48 x 10 ⁶	41.7	positrons
¹³ N	whole body	0.85 x 10 ⁷	6.95	annihilation
¹⁵ O	skin	0.74 x 10 ⁶	41.7	positrons
¹⁵ O	whole body	0.85 x 10 ⁷	6.95	annihilation

Table 7-6 Activity production rates (P) for various x-ray beams and a 0.2 x 0.2 m² field*

Megavoltage (MV)	Isotope	P (Bq kg ⁻¹ N ₂)	Isotope	P (Bq kg ⁻¹ O ₂)
15	¹³ N	1.05	¹⁵ O	0.00
18		2.3		0.32
20		3.0		1.0
25		6.5		6.2
33		8.1		14.0
45		10.0		15.2

*The dose rate at the isocenter is 16.7 mGy s⁻¹.

The total dose equivalent to the skin of a technologist in a year's time was calculated by McGinley et al. (1984) for the treatment of 40 patients per day, five days per week, and 4 Gy daily dose per patient. A daily treatment time of 120 s and 600 s stay time per patient was assumed for the evaluation. It was found that the skin dose equivalent was well below the maximum permissible dose equivalent of 0.5 Sv used at the time of the study and that air activation represents a minimal hazard to the technologist.

Atrium

In order to create a more pleasant atmosphere in the treatment room, a few facilities have used an atrium or skylight located in the secondary portion of the ceiling. Figure 7-5 shows a room with an atrium in the shape of a triangle with sides 5.94 m, 4.00 m, and 4.40 m in length. The accelerator was operated in the 18 MV x-ray mode with the collimator fully open (0.4 × 0.4 m²) and a dose rate of 5.0 cG s⁻¹ at the isocenter. The results of a radiation survey conducted with the beam directed vertically up are shown in Table 7-7. The dose equivalent rate at the outside of the atrium was on the order of 18 nSv s⁻¹ for neutrons and 5 nSv s⁻¹ for photons. The dose equivalent rate as one moves away from the building at ground level increases up to a distance of 16.5 m from the isocenter and then drops off with increasing distance.

The radiation level inside the building was found to increase as one moves from the first to third floor. The total dose equivalent on the third floor exceeds the limit of 0.02 mSv per week for uncontrolled areas if one assumes a workload greater than 2.8 × 10⁴ cGy in seven days and an occupancy factor for the third floor of one.

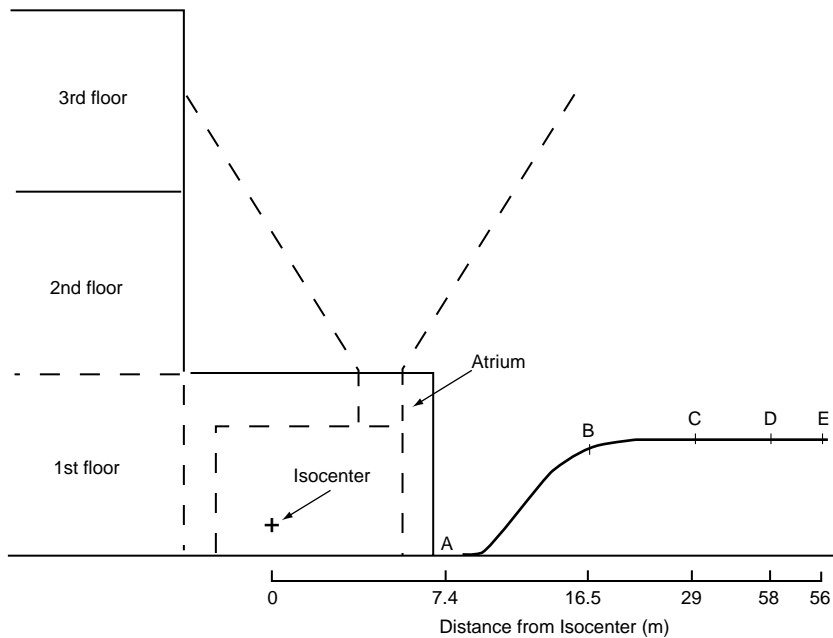

Figure 7-5. Treatment room with an atrium

Table 7-7 Photon and neutron dose equivalent rates in the vicinity of an 18 MeV accelerator room

Location (see figure 7-5)	Distance from isocenter (m)	Neutron rate ($nSv s^{-1}$)	Photon rate ($nSv s^{-1}$)
A	7.4	0.39	0.28
B	16.5	0.45	0.56
C	29.0	0.36	0.15
D	50.0	0.14	0.15
E	56.0	0.11	0.15
2nd floor	—	1.47	1.08
3rd floor	—	2.78	1.08

An additional problem that is created by the use of an atrium is the high level of light in the treatment room, which may make it impossible to see the light beam representing the radiation field on the patient's skin. As a result of this problem, it may be necessary to have

blinds on the atrium that automatically shut when the radiation field light is illuminated.

Alternate Shielding Materials

A number of materials other than concrete, steel, and lead can be used for radiation shielding purposes. For example, the room without a ceiling shielding that was described in the skyshine section of this chapter was modified by adding a 10 cm layer of asphalt to the roof. This material is rich in hydrogen, so it is a good fast neutron shield and the slow neutron flux will be reduced by hydrogen capture reactions. However, the photon dose level will be only slightly attenuated by the asphalt. A reduction of the neutron dose equivalent by a factor of approximately 10 was observed with the asphalt roof coat in place. It would be possible to add a strong slow neutron absorber such as boron to the asphalt and enhance the slow neutron shielding properties of the material.

Water is a hydrogenous material in which a boron compound such as borax or boric acid can be dissolved. The author and co-worker Jeffrey Long have fabricated a low-cost “water” door for a treatment room by filling a stainless steel door case with borated water (U.S. Patent No. 4833335). To eliminate the possibility of water leakage and evaporation, a polyester resin that forms a gel with the water can be added. The door was placed at the inner maze entrance to prevent neutrons from entering the maze, thereby reducing the dose equivalent due to capture gammas and neutrons at the outer maze entrance. Measurements were made outside the water door, and values of 7.5 cm and 21.5 cm of water were found for the TVL for neutrons and photons, respectively. The accelerator was operated in the 20 MV x-ray mode, and the isocenter was visible from the door opening. With a moderate length maze an additional shielded door is not needed at the outer maze entrance. The total cost of the water door was approximately \$2000 as compared with a typical lead and polyethylene door, which has a cost of \$30,000 to \$50,000.

High density (HD) concrete blocks are available for the construction of shielded rooms for medical accelerators. The use of HD block permits a reduction in the shield thickness, floor space, and structure height as compared to cast concrete construction. The reduced room height allows the accelerator room to be constructed within a single

story level. On the other hand, concrete rooms typically require one and a half floor levels. Rooms constructed of HD block can be moved or later modified to accept a higher energy accelerator. HD block has a number of advantages over lead shielding since it is nontoxic, costs less, and has neutron attenuation similar to ordinary concrete.

The blocks are usually manufactured in fixed dimensions of $15.2 \times 15.2 \times 30.5$ cm ($6 \times 6 \times 12$ in.) and are designed to interlock on all sides to prevent radiation leakage. The blocks are fabricated of a mixture of about 50% iron or steel fragments and 50% cement by volume. Blocks with density in the range of 3.52 to 5.13 g/cm³ (220 to 320 lb/ft³) are commercially available. If the shield thickness requirement is such that a whole number of blocks is not required, the barrier can be fabricated of blocks with different density to achieve the desired attenuation. Limited shielding data are available in the literature for HD blocks. Barish (1993) has published primary TVLs for 6, 8, and 16 MV x-rays. Broad beam TVLs of 0.162, 0.179, and 0.211 m were found for the attenuation of 6, 8, and 16 MV x-rays in 4.7 g/cm³ HD block. Based on measurements for the 16 MV x-ray beam a TVL of 29 cm was found for the photoneutrons as compared to 21 cm for ordinary concrete. Values of the TVL in HD block used for secondary barriers are not available in the literature for either photons or photoneutrons. Since HD block attenuates neutrons less efficiently than ordinary concrete, it is possible to have a situation where a secondary barrier provides adequate protection for x-rays but not for neutrons. This condition never occurs for ordinary concrete barriers because the thickness is about twice that of a HD block barrier. Steel beams and columns, which offer little neutron attenuation, are used to stabilize HD block rooms. It may be necessary to add neutron shielding such as polyethylene to structural steel within the block barriers. Beams made of ordinary concrete offer less shielding than HD blocks and additional photon shielding will be required.